

# Diaphragm Seals

for Homogenizing Systems, PN 600 (10,000 lb/sq.in.)

Model **MDM 7390**

## Application

Diaphragm seals model MDM 7390 are especially designed for applications at homogenizing systems for pressure ranges from 0/10 bar up to 0/600 bar (0/150 to 0/10,000 psi).

Bourdon tube pressure gauges of nom. size 100 (4") are the most common type of measuring instruments mounted to a diaphragm seal model MDM 7390. But also pressure gauges of other case sizes, pressure switches, pressure transmitters, and others can be provided with our MDM 7390.

## Construction

The membrane is flush welded to the body. The diaphragm seals are provided with a filling port in the holding collar to simplify the filling of the complete measuring system after mounting and evacuating the system. A special screw closes the filling port afterwards. This screw may not be opened.

If mounted directly, without cooling element or capillary line, the pressure gauge is welded to the diaphragm seal.

## Standard Configuration

### Body with Holding Collar

316 stainless steel (1.4571)

### Instrument Connection

G  $\frac{3}{8}$  female (  $\frac{3}{8}$ " BSP female)

(If the measuring instrument is mounted without cooling element or capillary line, it will be welded to the diaphragm seal.)

### Diaphragm

316 stainless steel (1.4435), flush welded to the body, effective diameter of the membrane  $\varnothing d_M = 21$  mm (.83")

### Process Connection

Connection for homogenizing systems  $\varnothing 23.8$  (.94"), immersion length 13 mm (.51")

Optional with attachment block flange made of 304 stainless steel (1.4301), 95 x 43 x 28 mm (3.74 x 1.69 x 1.10"), 2 holes  $\varnothing 17.5$  mm (.69"), distance 60.5 mm (2.38")

### Pressure Ranges

Bourdon tube pressure gauges nom. size 100 (4"):  
0/10 bar to 0/600 bar resp. 0/150 psi to 0/10,000 psi,  
also vacuum and compound ranges;  
for other instruments upon request

### Filling Fluid

Glycerine

### Reference Temperature

+20 °C (+68 °F)

### Dimensional Drawings

See overleaf

Further details about advantages and performances of chemical seals, and important explanations about the required ordering information are on general information leaflet 7000, where you will also find an overview of other chemical seal models.



MDM 7390



MDM 7390, here with attachment block flange (available at option)

## Optional Special Configurations

- O-ring recess upon request
- Attachment flange with 4 holes; union nut or others upon request
- Other filling fluids upon request
- Special versions with other dimensions upon request
- Capillary line between measuring instrument and diaphragm seal
- Ambient or medium temperature differing from +20 °C (+68 °F) (Please state all relevant details of the working conditions!)
- Cooling element between diaphragm seal and measuring instrument (e.g. urgently required if the medium temperature is >100 °C [+212 °F] and no capillary line is used)
- Special materials upon request

### How to Order:

Please note the detailed information about how to order on our general information leaflet 7000 and on the data sheet for the measuring instrument that shall be attached.

Model code: **MDM 7390**

Instrument connection: **G  $\frac{3}{8}$  female ( $\frac{3}{8}$ " BSP)**

Material: 316 stainless steel (1.4571)

Process connection: Standard (for homogenizing systems); optional with attachment block flange (extra charges)

Special options: see above

Please quote the process and ambient temperatures when different than +20 °C (+68 °F), resp. when special cleaning conditions or other special conditions occur.



**ARMATURENBAU GmbH**

Manometerstraße 5 • D-46487 Wesel - Ginderich  
Phone: (0 28 03) 91 30-0 • Fax: (0 28 03) 10 35  
armaturenbau.com • mail@armaturenbau.com



Subsidiary Company and Sales East Germany and Eastern Europe

**MANOTHERM Beierfeld GmbH**

Am Gewerbepark 9 • D-08340 Beierfeld  
Phone: (0 37 74) 58 - 0 • Fax: (0 37 74) 58 - 545  
manotherm.com • mail@manotherm.com

**7390**  
**3/03**

# Dimensional Drawings, Data and Weight

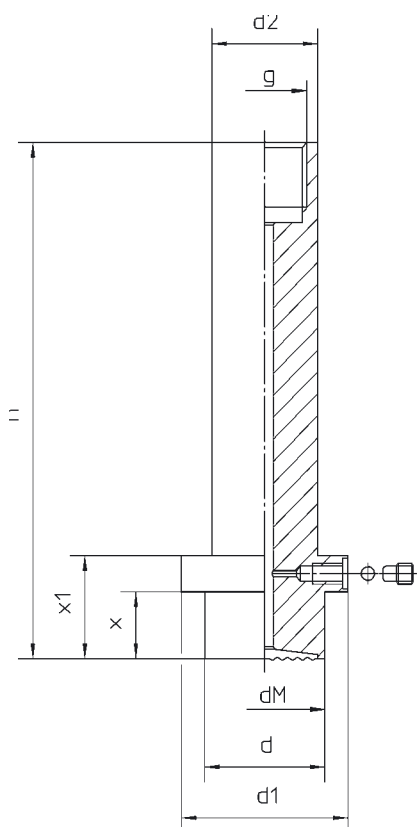

Available at option:  
Attachement block flange

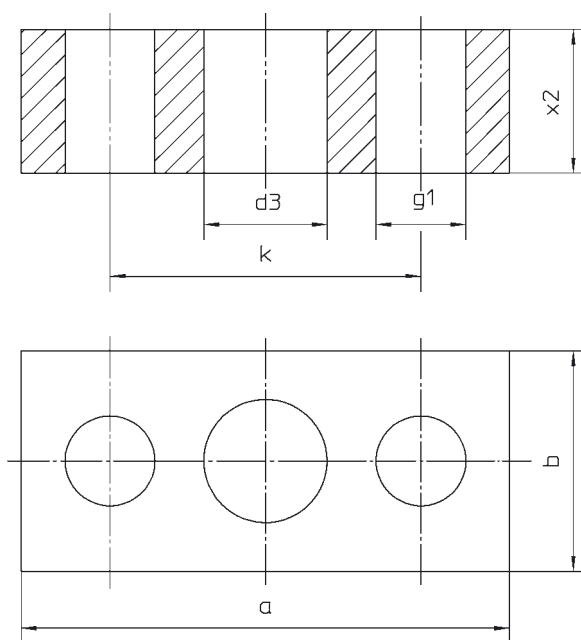

Dimensions ( mm / inches ) and Weight ( kg / lb )

a	b	d	d1	d2	d3	dM	g	g1	h	k	x	x1	x2	Weight (approx.) Diaphragm Seal	Weight (approx.) Attachement Flange (at Option)
95	43	23.8	33	21	24	21	G 3/8	Ø 17.5	100	60.5	13	20	28	.290	.710
3.74	1.69	.94	1.3	.83	.94	.83	3/8" BSP	.69	3.94	2.38	.51	.79	1.10	.64	1.57

The information in this leaflet is given in good faith, but we reserve the right to make changes without notice.