

Bimetal Thermometers, Rigid Mount

Crimped-on ring case stainless steel

TBiSChg
TBiSChgG

Standard Versions

Information on general and metrological features (e.g temperature resistance) and temperature ranges / error limits / smallest subdivision can be found in model overview 8000.

Measuring Unit

Helical bimetallic element

Accuracy (EN 13 190)

Class 1

Case

With polished crimped-on ring, 1.4301 (304 stainless steel)

Case Protection Type (EN 60 529 / IEC 529)

IP 65

Case Filling

For model TBiSChgG

temperature ranges - 20 °C up to +100 °C:

glycerine

temperature ranges - 40 °C and +100 °C and above up to 250 °C:

silicone oil

Nominal Case Sizes

63, 80, 100, 125, 160 (mm) (2½", 3", 4", 5", 6")

Case Configuration

Connection temperature

sensor (stem): rigid mount with neck tube

Stem position: vertical bottom position (not for NCS 160)

optional: centre back position (**rm**):

for stem B1 and B4.1

without neck tube, see page 2

Mounting device: without

Temperature Ranges (EN 13 190)

Spans from 60 K to 600 K

Temperature Sensor (Stem)

1.4571 (316 stainless steel),

max. static operating pressure: 25 bar

Stem models: B1, B3, B4, B4.1, B5 or B6,

Stem- Ø dF: 6 or 8 mm

Stem length L: Lmin resp. L1min up to max. 400 mm

Please regard the minimum stem length depending on the active length (La) and stem model, see page 3.

Window

Instrument glass

Dial

Aluminum, black figures, white background

Pointer

Aluminum, black

Indication Adjustment (± 4%)

Externally by a screw



Ordering Information, Standard Temperature Ranges, Options

See page 4

Special Versions and further Options among others

- Other connection threads and materials upon request
- Other temperature ranges and/or special scales, e.g. dual scale °C/°F, coloured fields or areas, dial inscriptions, etc.
- Case parts 1.4404 (316 stainless steel) upon request
- Model TBiSChg for ambient temperatures up to -60 °C; Model TBiSChgG for ambient temperatures up to -40 °C; up to -60 °C NCS 100, 125 and 160
- Position of the connection radial at 3 o'clock, 9 o'clock, 12 o'clock, others upon request or other than vertical installation (90°)
- GOST-version for Russia, Ukraine, Kazakhstan

Thermowells

See DS 8.8110 ff



Sales and Export South, West, North

ARMATURENBAU GmbH

Manometerstraße 5 • D-46487 Wesel - Ginderich
Tel.: +49 (0)28 03/91 30-0 • Fax: +49 (0)28 03/10 35
armaturenbau.com • mail@armaturenbau.com

Subsidiary Company, Sales and Export East

MANOTHERM Beierfeld GmbH

Am Gewerbepark 9 • D-08344 Grünhain-Beierfeld
Tel.: +49 (0)37 74/58-0 • Fax: +49 (0)37 74/58-545
manotherm.com • mail@manotherm.com

8102

06/13

Stem Position / Case Configurations, Code Letters, Dimensional Data and Weights

Vertical Bottom Stem Position

without additional code letter

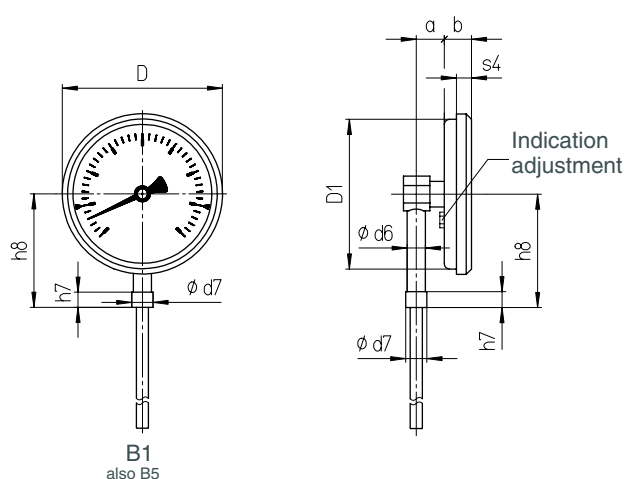

Further Stem Models

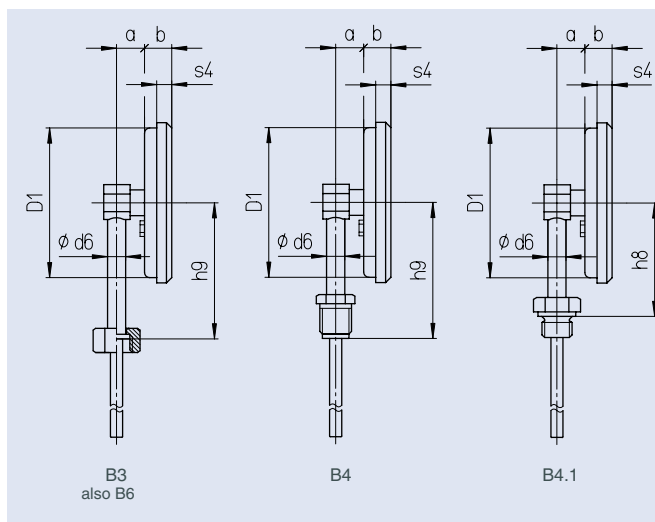

Centre Back Stem Position

Code letters rm

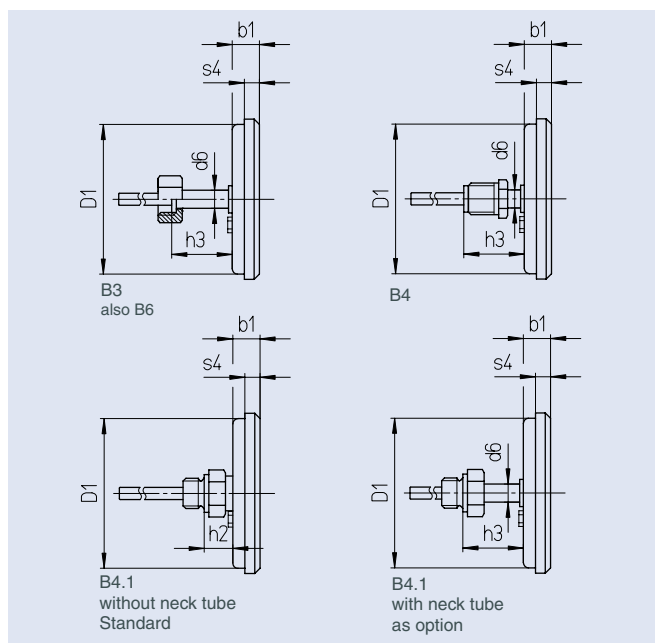
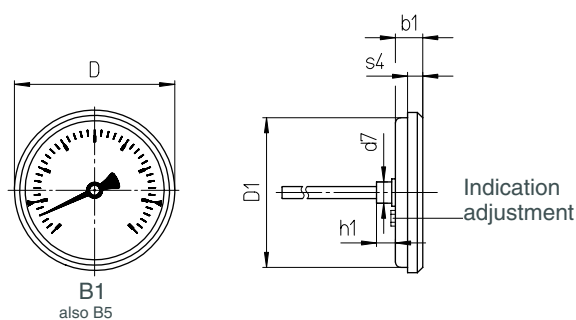

Dimensional Data (mm / inches) and Weights (kg / lb)

NCS	a	b	b1	D	D1	d6	d7	h1	h2	h3 ¹⁾	h7	h8	h9	s4	approx. weight ²⁾	
															TBiSChg	TBiSChgG
63	18.5	17	17	67	62	12	14	12.5	19	40	10.5	55	70	8	0.18	0.20
2½"	.73	.67	.67	2.63	2.44	.47	.55	.5	.75	1.57	.41	2.17	2.76	.31	0.39	0.44
80	18.5	18	18	86	79	12	14	12.5	19	40	10.5	65	80	8	0.22	0.27
3"	.73	.71	.71	3.39	3.11	.47	.55	.5	.75	1.57	.41	2.56	3.15	.31	0.48	0.59
100	18.5	18	18	106	98	12	14	12.5	19	40	10.5	75	90	10	0.29	0.37
4"	.73	.71	.71	4.17	3.86	.47	.55	.5	.75	1.57	.41	2.95	3.54	.4	0.63	0.81
125	18.5	20	20	136	125	12	14	12.5	19	40	10.5	85	102	11	0.36 ³⁾	0.47 ³⁾
5"	.73	.79	.79	5.35	4.92	.47	.55	.5	.75	1.57	.41	3.35	4.02	.43	0.79	1.04
160	-	-	21	167	159	12	14	12.5	19	40	-	-	-	11	0.46 ³⁾	0.66 ³⁾
6"	-	-	.83	6.57	6.26	.47	.55	.5	.75	1.57	-	-	-	.43	1.01	1.45

¹⁾ Stem model B4 with G ¾ B: 50 mm (1.97")

²⁾ The information is an example and relates on version with stem B1, Ø 8 mm (0.3"), length 100 mm (4").

³⁾ Valid for model ...rm

Stem Models

Stem Models

Process connection:	without screw fitting, plain stem		
Stem model:	B1		
Form according to DIN 13 190:	Form 1		
Stem material:	1.4571		
Stem-Ø dF:	6 or 8		
Order length:	L		
Accessories:			
Data sheet (suitable thermowell models):	8.8140 (SK1), 8.8141 (SK2) 8.8150 (SK3.B), 8.8151 (SK4.B)		

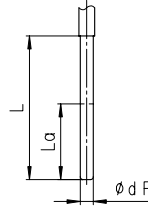

Process connection:	Union nut	Male thread, turnable	Male thread, rigid
Stem model:	B3	B4	B4.1
Form according to DIN 13 190:	Form 5	Form 4	Form 6 (thread cylindrical) Form 7 (thread conical)
Stem material:	1.4571	1.4571	1.4571
Stem-Ø dF:	6 or 8	6 or 8	6 or 8
Screw fitting material:	1.4571	1.4571	1.4571
Order length:	L	L	L
Accessories:			
Data sheet (suitable thermowell models):	8.8111 (SF4.1), 8.8113 (SF4.1F) 8.8130 (SF8), 8.8131 (SF9)	8.8110 (SF4), 8.8112 (SF4F) 8.8120 (SF5), 8.8121(SF6+SF7)	8.8110 (SF4), 8.8112 (SF4F) 8.8120 (SF5), 8.8121(SF6+SF7)

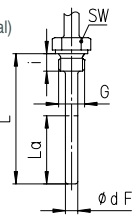
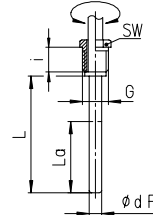
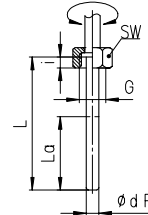

Thread (dimension in mm):	G	SW	i	G	SW	i	G	SW	i
	G ½	27	10	G ½ B	22	20	G ½ B	27	14
	G ¾	32	12	G ¾ B	27	23	G ¾ B	32	16
	M 20 x 1.5	27	10	M 18 x 1.5	22	14	½" NPT	27	19
	M 24 x 1.5	32	12	M 20 x 1.5	22	20	¾" NPT	27	19
	M 27 x 2	32	12				M 18 x 1.5	24	14
						M 20 x 1.5	27	14	

Thermowell required!

Process connection:	Male thread / compression fitting	Male thread, turnable / double male adapter
Stem model:	B5 (= basic stem B1 with compression fitting)	B6 (= basic stem B3 with double male adapter)
Form according to DIN 13 190:	Form 2 (thread cylindrical) Form 3 (thread conical)	—
Stem material:	1.4571	1.4571
Stem-Ø dF:	6, 8	6, 8
Screw fitting material:	1.4571	1.4571
Order length:	L	L1
Accessories:		
Data sheet (suitable thermowell models):	8.8110 (SF4), 8.8112 (SF4F) 8.8120 (SF5), 8.8121(SF6+SF7)	8.8110 (SF4), 8.8112 (SF4F) 8.8120 (SF5), 8.8121(SF6+SF7)

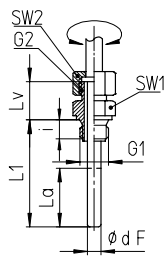
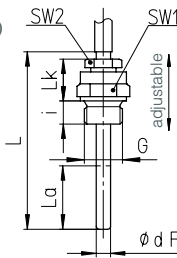

Thread (dimensions in mm):	G	SW1	SW2	i	Lk	G1	G2	SW1	SW2	i	Lv
	G ½ B	27	22	14	42	G ½ B	G ½ B	27	27	14	28
	G ¾ B	32	22	16	42	G ¾ B	G ½ B	32	27	16	28
	½" NPT	27	22	19	42	½" NPT	G ½ B	27	27	19	28
	¾" NPT	27	22	19	42	¾" NPT	G ½ B	27	27	19	28
	M 20 x 1.5	27	22	14	42	M 20 x 1.5	M 20 x 1.5	27	27	14	28
						M 24 x 1.5	M 20 x 1.5	32	27	14	28
					M 27 x 2	M 20 x 1.5	32	27	16	28	

Minimum Stem Length, Active Length and maximum realisable Stem Length

Stem model:	Length:	Thread:	Stem-Ø dF:						The minimum length Lmin / L1min of the stem is the smallest possible stem length depending on the active length La (sensitive portion) and the stem model.
			6		8		The active length La of the stem has to immerse completely into the medium, to grant a measuring result, which corresponds to the accuracy class.		
			≥ 100 K	= 80 K	= 60 K	≥ 80 K		= 60 K	
all models	La	all standard threads	40	60	70	40	60		
B1 B4	Lmin	all standard threads	45	65	75	45	65		
B3	Lmin	all standard threads	52	72	82	52	72		
B4.1	Lmin	all standard threads	60	80	90	60	80		
B5	Lmin	all standard threads	95	115	125	95	115		
B6	L1min	all standard threads	60	80	90	60	80		
others			upon request			upon request			

¹⁾ The temperature difference ΔT = 60 K corresponds to the e.g. the temperature range 0/60 °C, but also -20/40 °C, see table on page 4

Ordering Information with Indication- and Temperature Ranges, Options

Basic Model: Bimetal thermometers with rigid mount to stem		TBiSChg
Case filling:	according to version glycerine or silicone oil	G
Nominal case size:	case-Ø 63, 80, 100, 125, 160 (mm) (2½", 3", 4", 5", 6")	63, 80, 100, 125, 160
Stem position / case configuration:	vertical bottom position centre back position	without code letters rm
Temperature ranges:	ΔT (K):	
	0 — 60 °C 60	
	0 — 80 °C 80	
	0 — 100 °C 100	e. g. 0-100 °C
	0 — 120 °C 120	
	0 — 160 °C 160	
	0 — 200 °C 200	
	0 — 250 °C 250	
	0 — 300 °C 300	
	0 — 400 °C 400	
	0 — 500 °C 500	
	0 — 600 °C 600	
	-50 / + 50 °C 100	
	-40 / + 40 °C 80	
	-40 / + 60 °C 100	
	-30 / + 50 °C 80	e. g. -30/+50 °C
	-30 / + 70 °C 100	
	-20 / + 40 °C 60	
	-20 / + 60 °C 80	
	-20 / + 80 °C 100	
	+50 / +300 °C 250	
Stem:	without screw fitting, plain stem	B1
	union nut	B3
	male thread, turnable	B4
	male thread, rigid	B4.1
	male thread / compression fitting	B5
	male thread, turnable / double male adapter	B6
Stem-Ø dF:	6 or 8 mm	dF 6, 8
Stem length:	L resp. L1 in mm	e. g. L = 100 mm
Process connection:	see page 3	e. g. G ½ B
Options:	red mark on the dial	
	plastic clip red or green external at bayonet ring for NCS 80, 100,125 and 160	
	window tempered safety glass for NCS 80, 100,125 and 160	
	acrylic glass (PMMA) for NCS 80 and 100	
	polycarbonate (PC) NCS 63, 80 and 100	
	case polished	
	neck tube for stem B4.1 and centre back connection	<i>(order at the moment still as cleartext)</i>
	stem- Ø dF 10 mm	
	case filling indication ranges from - 20 °C up to +100 °C: silicone oil	
	stem length > 400 mm, max. 800 mm	
	measuring point stainless steel-plate 12 mm x 55 mm (0.47" x 2.17"), wire mounting or	
	marking sticker on case coverage	
Example:	TBiSChg 80rm, 0-100 °C, B3, dF 6, L = 100 mm, G ½	

Example: **TBiSChg 80rm, 0-100 °C, B3, dF 6, L = 100 mm, G ½**

Special Versions: Please describe your requirements clearly

© 2013 ARMATURENBAU GmbH and MANOTHERM Beierfeld GmbH · Changes, replacement of materials and printing errors excepted