

SG2 Series

Regulators - Pressure Reducing

DSG022032X012

Specifications

For questions about this product, please consult TESCOM.

OPERATING PARAMETERS

Pressure rating per criteria of CGA E-4; ASME B31; ASME BPVC

Maximum Inlet Pressure

4500 psig / 310 bar

Maximum Outlet Pressure

15, 25, 50, 125, 250 psig
103, 172, 345, 862, 1724 kPa
1.0, 1.7, 3.4, 8.6, 17.2 bar

Design Proof Pressure

150% of rated pressure

Leakage

Internal: Bubble-tight

External: Designed to meet $< 2 \times 10^{-8}$ atm cc/sec He

Operating Temperature

PCTFE seat: -40°F to 140°F / -40°C to 60°C
Vespel® seat: -40°F to 250°F / -40°C to 121°C

Flow Capacity

$C_v = 0.06$

Decaying Inlet Characteristic

For Stainless Steel Diaphragm

-0.09 psig / -100 psig
-6 mbar / -6.9 bar

For Neoprene Diaphragm

-0.03 psig / -100 psig
-2 mbar / -6.9 bar



TESCOM SG2 Series is a compact, lightweight, high purity two-stage cylinder regulator for specialty, flammable and industrial gas flows of less than 4 SCFM / 112 SLPM. Sensitive, extra long-life metal diaphragm ensures gas purity and integrity. User-friendly model number enables the specifier to select optional gauges, relief and shut-off valves, and cylinder connections as part of the regulator assembly.

MEDIA CONTACT MATERIALS

Body

316L Stainless Steel, Nickel-Plated Brass

Seat

PCTFE, Vespel®

Diaphragm

316L Stainless Steel, Neoprene

Filter

10 micron nominal sintered Bronze
10 micron nominal sintered 316 Stainless Steel

Seal

Teflon® or Buna-N

Remaining Parts

Brass, 300 Series Stainless Steel

Applications

- Laboratory and Point-of-Use Gas Systems in medical, pharmaceutical, food and beverage and other high purity applications
- Process analyzer gases, metal fabrication and specialty and industrial gas cylinders

Features and Benefits

- Cartridge valve design incorporates 10 micron filter to protect the regulator seat and makes service simple
- Optional neoprene diaphragms provide exceptional sensitivity for precise pressure control

OTHERS

Connections

Inlet and outlet: 1/4" NPTF
Accessories: 1/4" NPTF

Cleaning

CGA 4.1 and ASTM G93

Weight

4.0 lbs / 1.8 kg

Teflon® and Vespel® are registered trademarks of E.I. du Pont de Nemours and Company.

SG2 Series Regulator Drawing

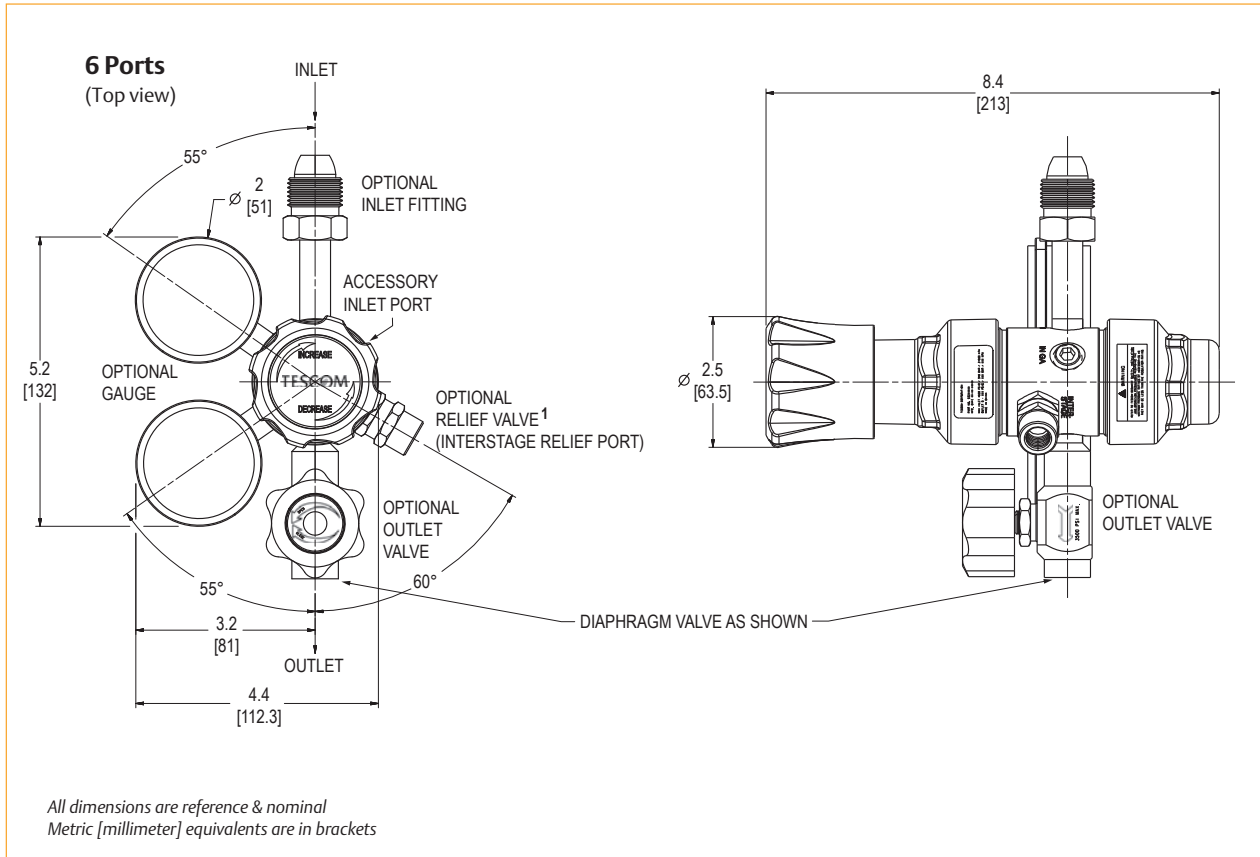

SG2 Series Regulator Flow Charts

For more information on how to read flow curves, please refer to the Flow Curves and Calculations document (debul2007x012) in the TESCOM catalog or on www.tescom.com.

C_v = 0.06 Model

Metal Diaphragm

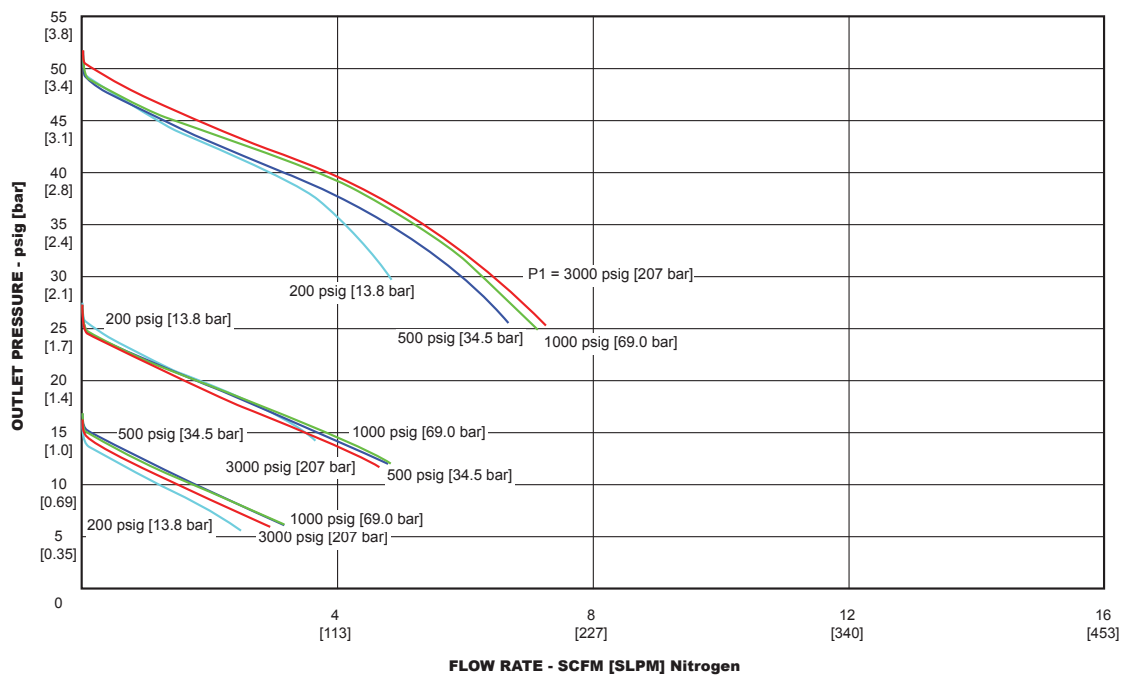
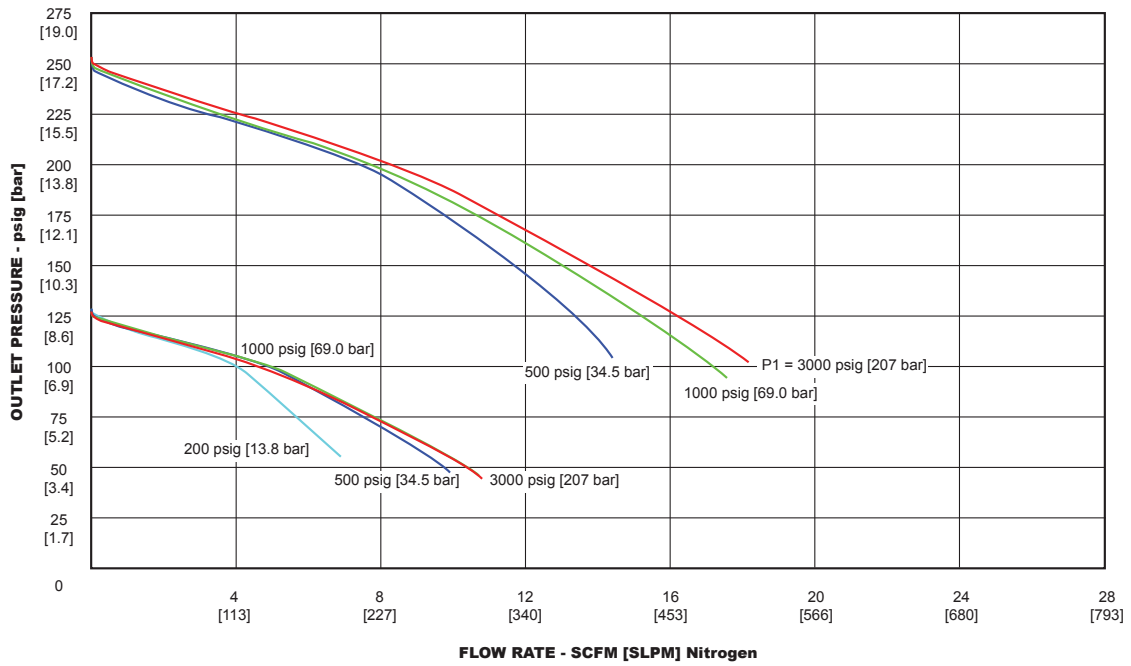

SG2 Series Regulator Flow Charts

For more information on how to read flow curves, please refer to the Flow Curves and Calculations document (debul2007x012) in the TESCOM catalog or on www.tescom.com.

$C_v = 0.06$ Model

Neoprene Diaphragm

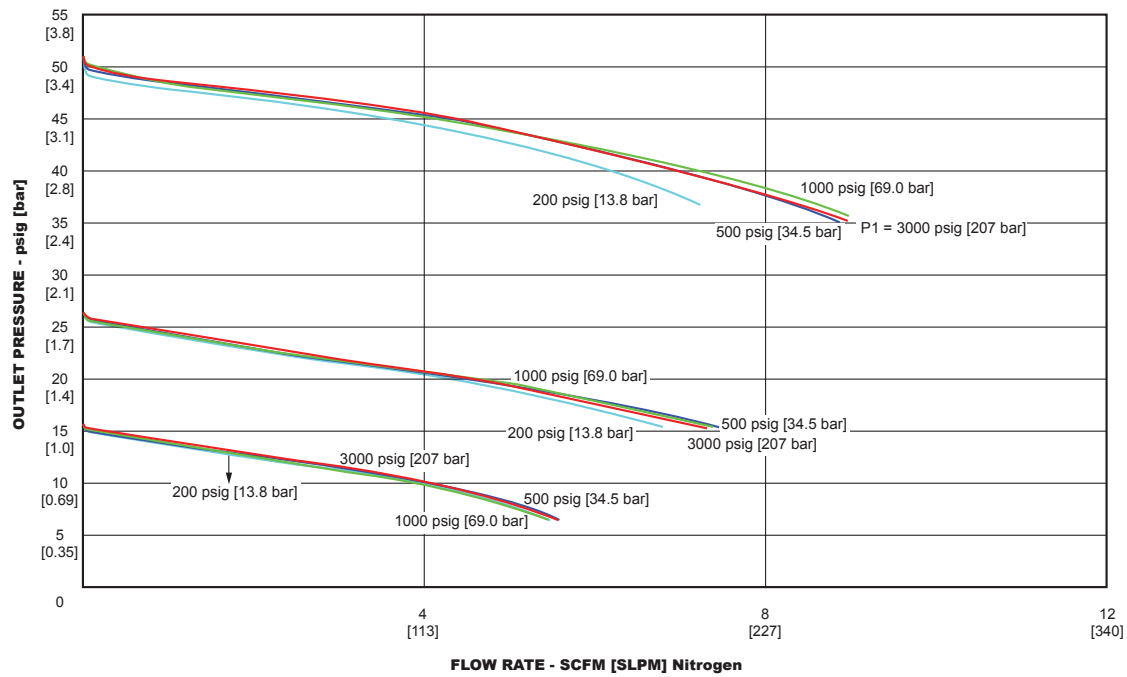
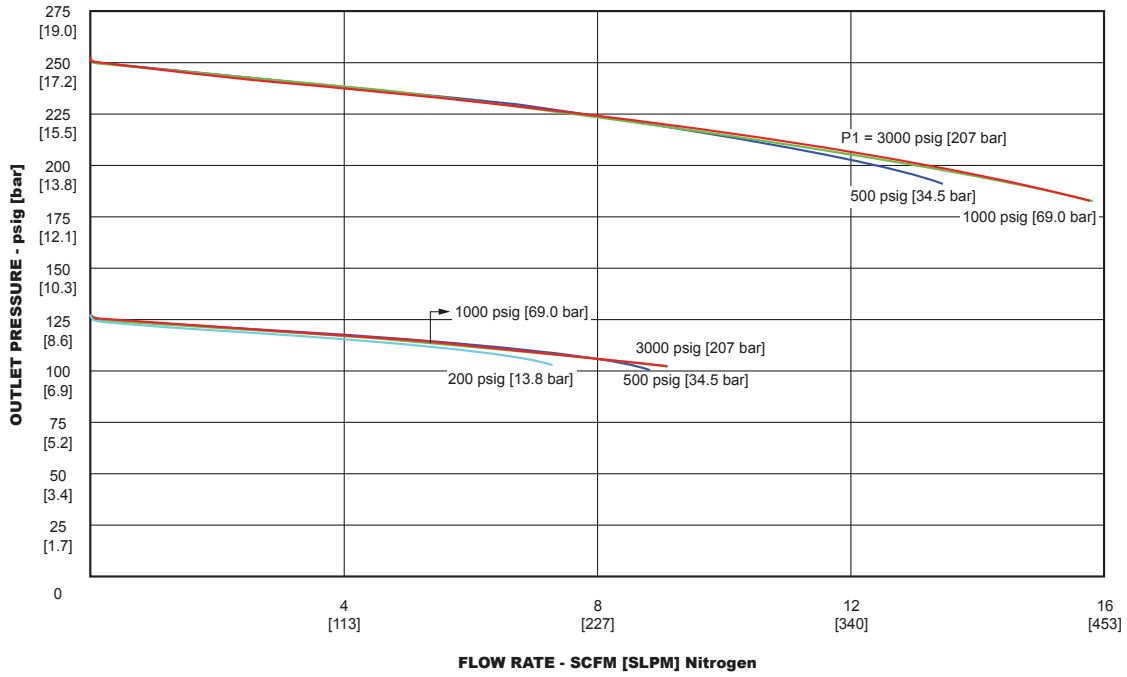

SG2 Series Regulator Part Number Selector

Repair Kits, Accessories & Modifications may be available for this product. Please contact TESCOM for more information.

Base Model

Example for selecting a part number:

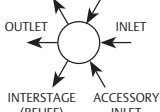
SG2	6	3	1	0	0	[Blank]	
BASIC SERIES	BODY MATERIAL	OUTLET PRESSURE RANGES	DIAPHRAGM MATERIAL	SEAL MATERIAL	PORTS ² (TOP VIEW)	C _v	SEAT MATERIAL
SG2	P – Nickel-Plated Brass 6 – 316L Stainless Steel	1 – 15 psig / 103 kPa / 1.0 bar * 2 – 25 psig / 172 kPa / 1.7 bar 3 – 50 psig / 345 kPa / 3.4 bar 4 – 125 psig / 862 kPa / 8.6 bar 5 – 250 psig / 1724 kPa / 17.2 bar	1 – 316L Stainless Steel 2 – Neoprene	Teflon® Buna-N	0 – 6 Port 	0 – 0.06	[Blank] – PCTFE V – VespeI®

Accessories

Extension to base model part number:

SG2XXXXXX	–	06	A	1	A
BASE MODEL NUMBER		CYLINDER CONNECTIONS	GAUGES ²	RELIEF VALVE ¹	OUTLET VALVE
00 – None 01 – CGA 296 02 – CGA 350 C1 – CGA 510 03 – CGA 540 04 – CGA 580 05 – CGA 590 06 – DIN 477-1.1 07 – DIN 477-1.3 08 – DIN 477-1.5 09 – DIN 477-1.6 10 – DIN 477-1.7 11 – DIN 477-1.8 12 – DIN 477-1.9 13 – DIN 477-1.10 14 – DIN 477-1.14 15 – DIN 477-5.54 16 – DIN 477-5.57 17 – DIN 477-5.59 18 – BS 341 (2003) #01 19 – BS 341 (2003) #02 20 – BS 341 (2003) #03 21 – BS 341 (2003) #04 23 – BS 341 (2003) #06 24 – BS 341 (2003) #07 25 – BS 341 (2003) #08 27 – BS 341 (2003) #10 28 – BS 341 (2003) #11 30 – BS 341 (2003) #13 31 – BS 341 (2003) #14 32 – BS 341 (2003) #15	0 – None P – Plug(s) A – psi / kPa B – bar / psi	A – None P – Plug 1 – Teflon® Pipe-away	0 – None A – Diaphragm Valve B – Needle Valve		

Note: Cylinder connections are available in all world areas.

¹ The relief valve is not intended to be a "Pressure Relief Device" as defined by ASME Boiler & Pressure Vessel Code - Section VIII, nor is it intended to be a "Safety Accessory" or "Pressure Limiting Device" as defined by the Pressure Equipment Directive (97/23/EC). The relief valve is intended to indicate a potential problem with the regulator and prevent further damage to the regulator. The relief valve is not intended to protect the downstream process equipment.

²GAUGE PRESSURE RANGES

OUTLET PRESSURE RANGE	OUTLET GAUGE PRESSURE RANGE
SG2X1XXXX – 15 psig / 103 kPa / 1.0 bar	0-30 psig / 200 kPa / 2 bar
SG2X2XXXX – 25 psig / 172 kPa / 1.7 bar	0-30 psig / 200 kPa / 2 bar
SG2X3XXXX – 50 psig / 345 kPa / 3.4 bar	0-60 psig / 400 kPa / 4 bar
SG2X4XXXX – 125 psig / 862 kPa / 8.6 bar	0-160 psig / 1100 kPa / 11 bar
SG2X5XXXX – 250 psig / 1724 kPa / 17.2 bar	0-300 psig / 2000 kPa / 20 bar
INLET PRESSURE RANGE	INLET GAUGE PRESSURE RANGE
All	6000 psig / 41,000 kPa / 400 bar

SG2 Series Rebuild Kits

Rebuild Kits include replacement cartridges, diaphragms, diaphragm seals and instruction sheet.

KIT PART NUMBER	FOR SG PART NUMBER
JT389-8935	SG2PX100
JT389-8936	SG2PX200
JT389-8937	SG26X100
JT389-8938	SG26X200
JT389-8935V	SG2PX100V
JT389-8936V	SG2PX200V
JT389-8937V	SG26X100V
JT389-8938V	SG26X200V