

DA Series

Regulators - Pressure Reducing

DDAXX1798X012

Specifications

For other materials or modifications, please consult TESCOM.

OPERATING PARAMETERS

Pressure rating per criteria of ANSI/ASME B31.3

Maximum Inlet Pressure

4500 psig / 310 bar

Outlet Pressure Ranges

50 mm Hg absolute - 15 psig / 1.0 bar

50 mm Hg absolute - 50 psig / 3.4 bar

50 mm Hg absolute - 100 psig / 6.9 bar

50 mm Hg absolute - 350 psig / 24.1 bar

Design Proof Pressure

150% maximum rated

Leakage

Internal, Bubble-tight

Operating Temperature¹

-15°F to 140°F / -25°C to 60°C

Flow Capacity

$C_v = 0.06$

Maximum Operating Torque

30 in-lbs / 3.4 N•m



TESCOM DA Series absolute pressure reducing regulator is designed with an elastomeric diaphragm and provides accuracy to +/- 0.1 psig / 0.007 bar. This regulator may be used to reduce pressure from a supply source up to 4500 psig / 310 bar into a vacuum environment.

MEDIA CONTACT MATERIALS

Body

Brass or Nickel Plated Aluminum

Diaphragm

Buna-N, Ethylene Propylene, or Viton®

Seat

Teflon® (Inlet 500 psig / 34.5 bar maximum), CTFE, or Vespel®

Friction Sleeve (inner)

Teflon®

Friction Sleeve (outer)

316 Stainless Steel

Filter (40 micron)

316 Stainless Steel

Remaining Parts

300 Series Stainless Steel

Applications

- Instrumentation testing
- Calibration equipment

Features and Benefits

- Compact in size and highly sensitive
- Economical
- Quick response and accurate diaphragm-type regulation
- Excellent repeatability
- Non-venting
- Low operating handknob torque
- Captured bonnet is available
- Panel mounting option is available
- Variety of porting options, body materials and soft goods

OTHER

Cleaning

CGA 4.1 and ASTM G93

Weight (without gauges)

Brass: 2.4 lbs / 1.1 kg

Aluminum: 1 lb / 0.5 kg

1. For extended temperatures from -40°F to 400°F / -40°C to 204°C, consult Tescom. Viton®, Teflon®, and Vespel® are registered trademarks of E.I. du Pont de Nemours and Company.

DA Series Regulator Drawing

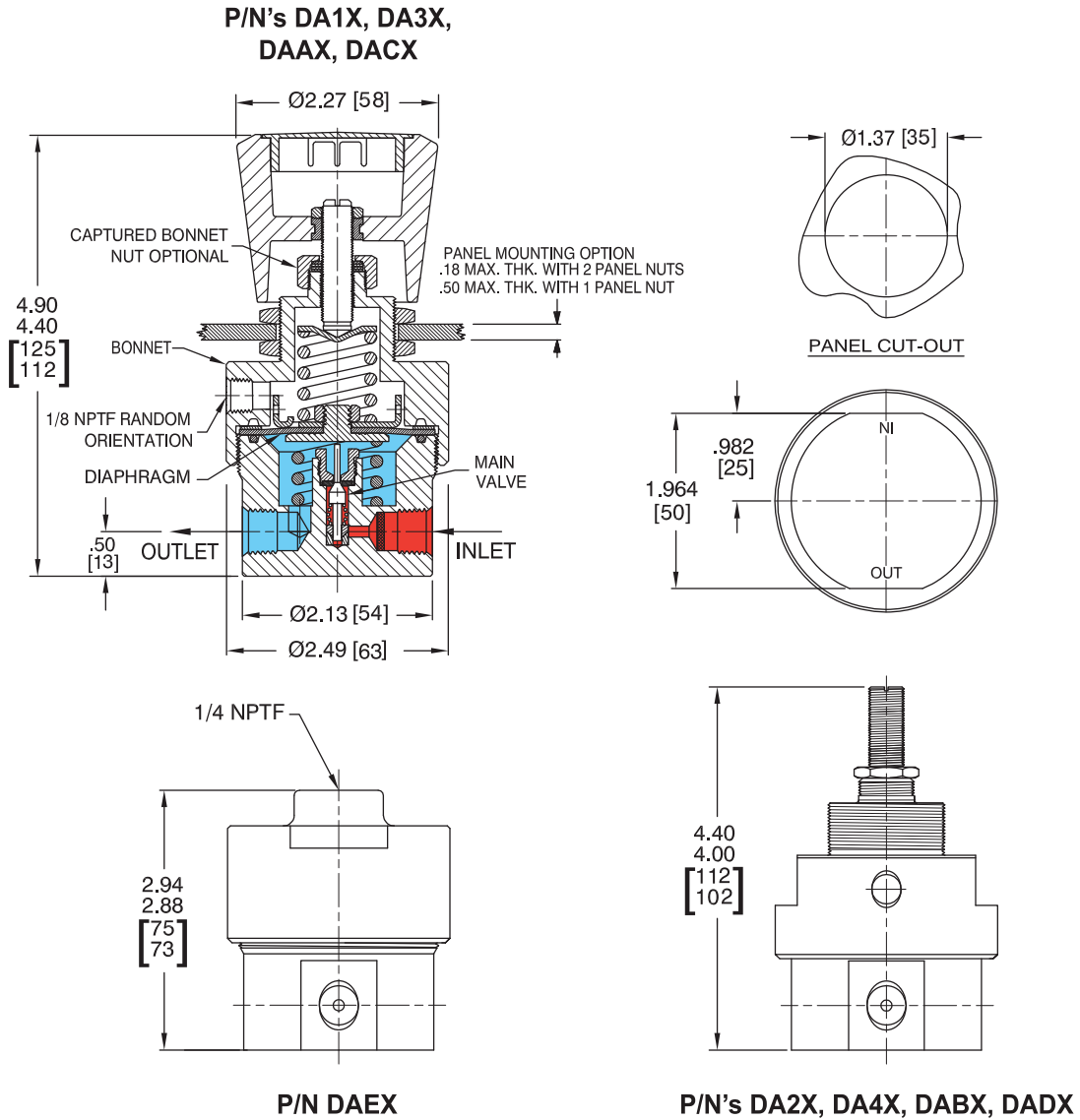

All dimensions are reference & nominal
Metric [millimeter] equivalents are in brackets

DA Series Regulator Flow Chart



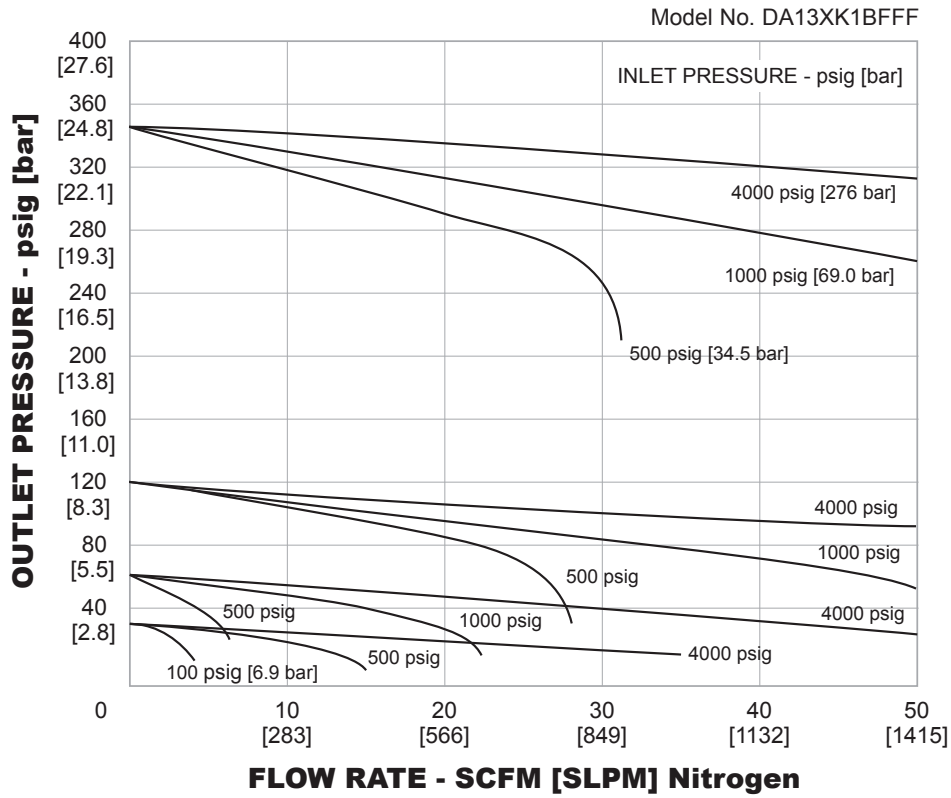

For more information on how to read flow curves, please refer to the Flow Curves and Calculations document (debul2007x012) in the TESCOM catalog or on www.tescom.com.



DA Series Regulator Part Number Selector

Repair Kits, Accessories & Modifications may be available for this product. Please contact TESCOM for more information.

Example for selecting a part number:

BASIC SERIES	LOAD TYPE	BODY MATERIAL	OUTLET PRESSURE RANGES		SEAT MATERIAL	FLOW C _v	DIAPHRAGM MATERIAL	MOUNTING	STANDARD PORTING CONFIGURATION	INLET, OUTLET AND GAUGE PORT TYPE AND SIZE
			STANDARD	ABSOLUTE ¹						
DA	Standard Pressure Reducing 1 – Handknob adjust 2 – Screwdriver adjust 3 – Captured bonnet Hand adjust 4 – Captured bonnet Screw adjust Absolute Pressure Reducing A – Handknob adjust B – Screwdriver adjust C – Captured bonnet Hand adjust D – Captured bonnet Screw adjust E – Dome loaded (maximum dome pressure 125 psig / 8.6 bar)	1 – Brass 3 – Aluminum	0 – N/A 1 – 0-15 psig 0-1.0 bar 2 – 0-50 psig 0-3.4 bar 3 – 0-100 psig 0-6.9 bar 4 – 0-350 psig 0-24.1 bar	50 mm Hg absolute - 100 psig / 6.9 bar (Dome loaded only) 50 mm Hg absolute - 15 psig / 1.0 bar 50 mm Hg absolute - 50 psig / 3.4 bar 50 mm Hg absolute - 100 psig / 6.9 bar 50 mm Hg absolute - 350 psig / 24.1 bar	K – CTFE Inlet 4500 psig / 310 bar maximum V – Vespel® Inlet 4500 psig / 310 bar maximum T – Teflon® Inlet 500 psig / 34.5 bar maximum	1 – C _v = 0.06	B – Buna-N E – Ethylene Propylene V – Viton®	9 – None P – Panel Mounting	A – No gauge ports  D – Out gauge port at 90°  B – In and Out gauge port at 60°  L – In and out gauge port at 90° 	B – 1/4" SAE F – 1/4" NPTF J – 1/4" MS33649 9 – None

1.28" Hg = 50 mm Hg absolute