

## Specifications

For other materials or modifications, please consult TESCOM.

### OPERATING PARAMETERS

Pressure rating per criteria of ANSI/ASME B31.3

#### Maximum Inlet Pressure

10,000 psig / 690 bar  
15,000 psig / 1034 bar

#### Maximum Outlet Pressure

Up to 10,000 psig / 690 bar standard

#### Design Proof Pressure

150% maximum rated

#### Leakage

**Non Metal Seat:** Bubble-tight

**Metal Seat:** 2 drops/minute at 150 SUS at 2500 psig / 172 bar

#### Operating Temperature

-15°F to 165°F / -26°C to 74°C

#### Flow Capacity

$C_v = 0.02, 0.06, 0.12$

### MEDIA CONTACT MATERIALS

#### Body

316 Stainless Steel

#### Seat, Vent and Main Valve

17-4 Stainless Steel, Vespel®

#### Back-up O-Rings

See Part Number Selector

#### Remaining Parts

300 Series Stainless Steel, 17-4 Stainless Steel, and Nitronic 60

### OTHER

#### Cleaning

CGA 4.1 and ASTM G93

#### Weight

5.5 lbs / 2.5 kg

Teflon®, Vespel®, and Viton® are registered trademarks of E.I. du Pont de Nemours and Company.



TESCOM 50-2000 Series pressure reducing regulator is specifically designed for extended life operation in high pressure hydraulic applications.

### Applications

- Wellhead control panels
- Subsea valve actuation
- Chemical injection
- Hydraulic Power Units (HPU)

### Features and Benefits

- New stem and seal design extends service life in crucial high pressure water-based hydraulic applications
- Specially designed seat and valve for excellent operation in hydraulic applications
- Segregated captured venting
- Tapered poppet design for better pressure control
- Higher pressure models are available

50-2000 Series Regulator Drawings

SPRING LOAD

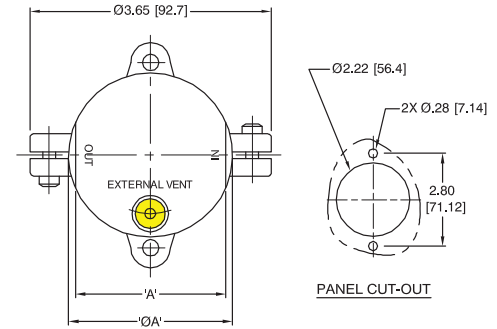
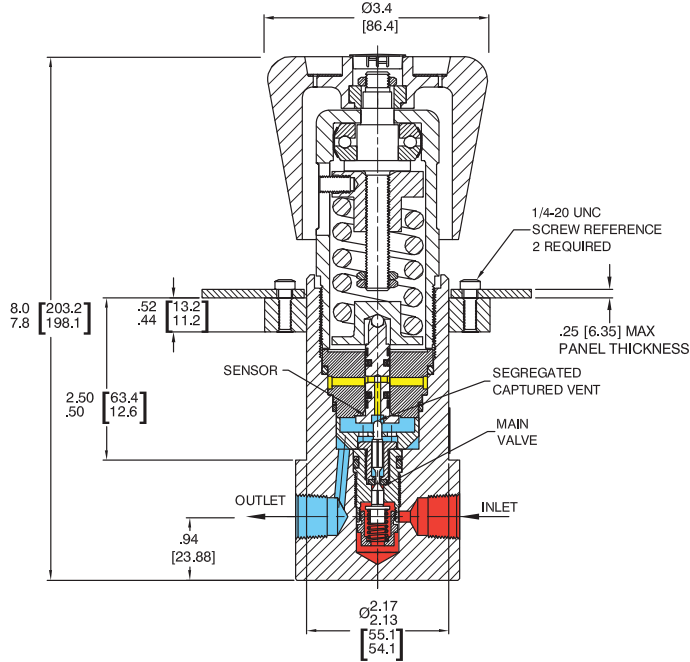

INLET & OUTLET PORT	'A'
ALL 1/4 EXCEPT NPTF	2.30
1/4 NPTF	Ø2.48
3/8 NPTF	Ø2.48
1/2 NPTF	Ø3.20
ALL 3/8 EXCEPT NPTF	2.90
1/2 MS33649	2.90

AIR LOAD

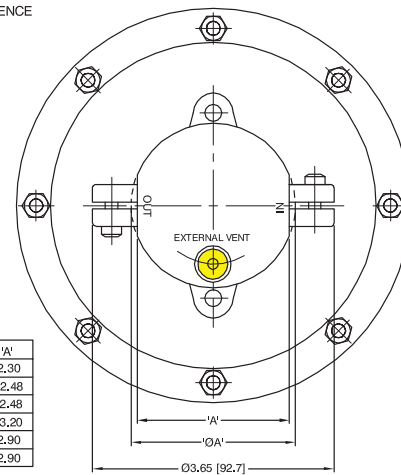
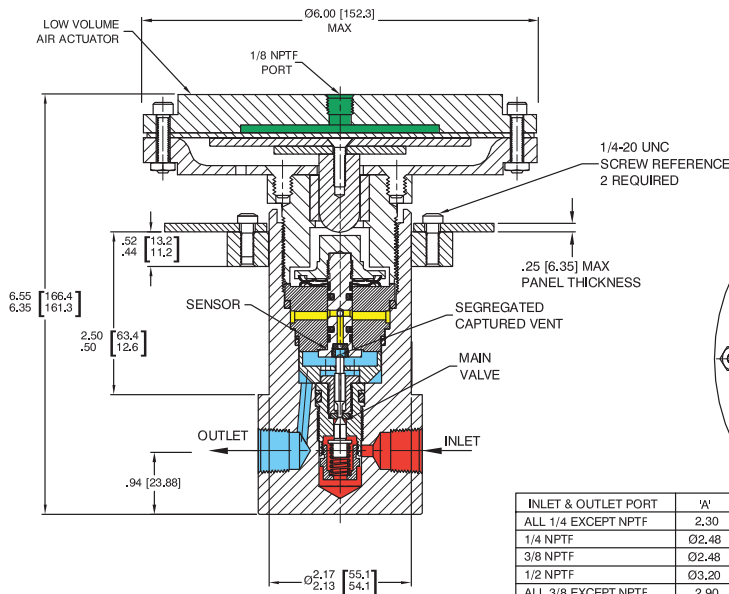

INLET & OUTLET PORT	'A'
ALL 1/4 EXCEPT NPTF	2.30
1/4 NPTF	Ø2.48
3/8 NPTF	Ø2.48
1/2 NPTF	Ø3.20
ALL 3/8 EXCEPT NPTF	2.90
1/2 MS33649	2.90

All dimensions are reference & nominal  
Metric [millimeter] equivalents are in brackets

### 50-2000 Series Regulator Flow Charts

For more information on how to read flow curves, please refer to the Flow Curves and Calculations document (debul2007x012) in the TESCOM catalog or on [www.tescom.com](http://www.tescom.com).

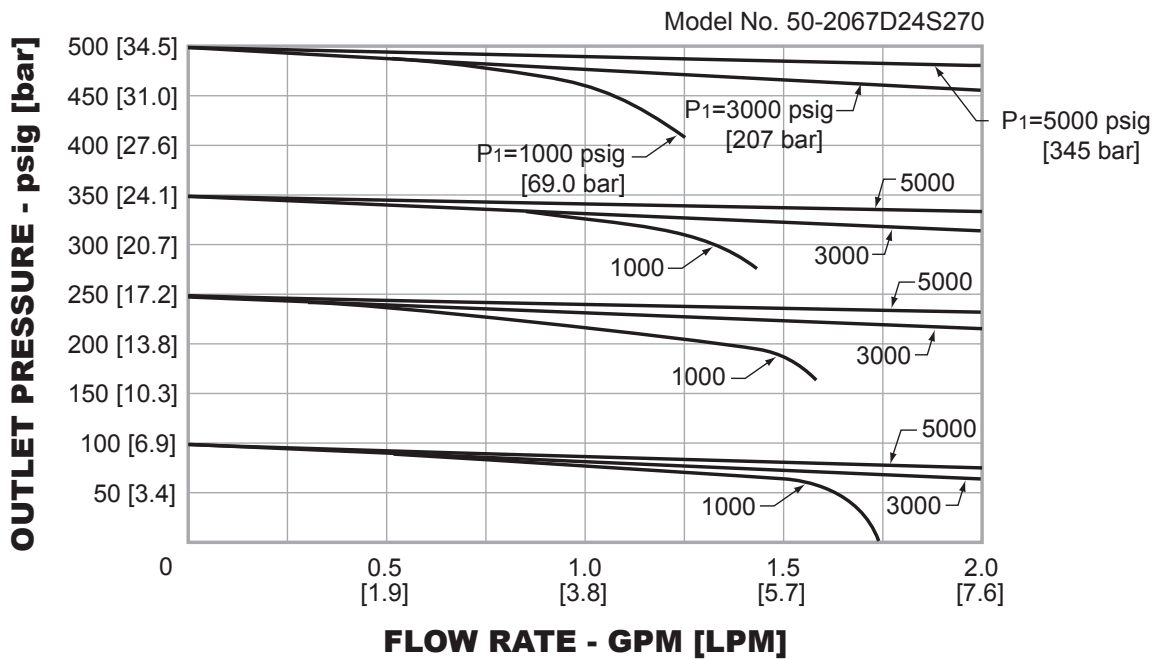
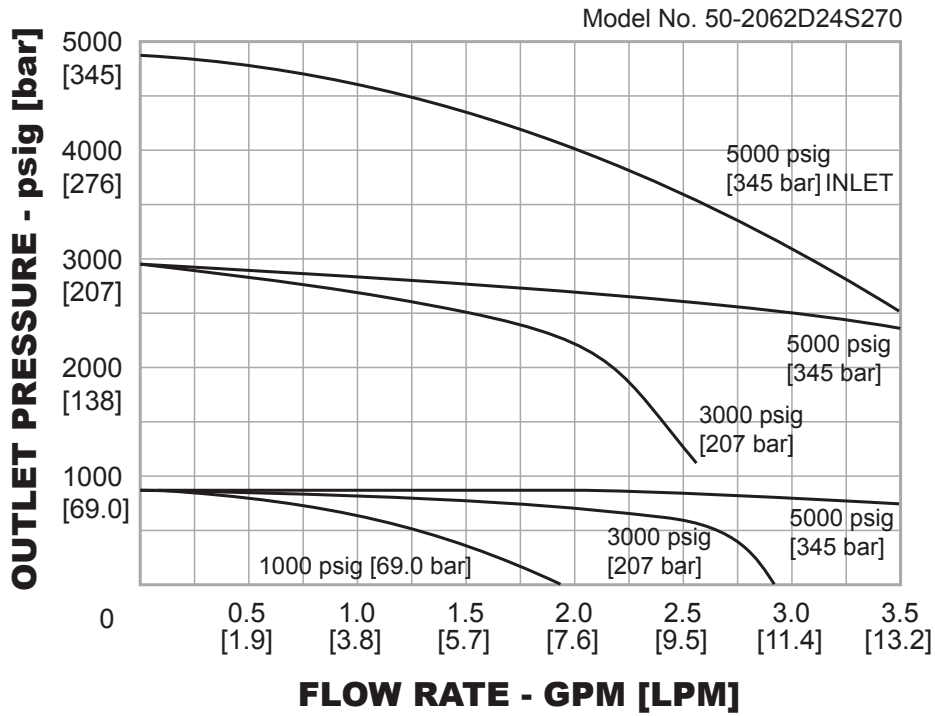







## 50-2000 Series Regulator Part Number Selector

Repair Kits, Accessories & Modifications may be available for this product. Please contact TESCOM for more information.

Example for selecting a part number:

S – Spring Load  
A – Air Load

50-20      6              1              -              D                      2              4      S              1              7              0

BASIC SERIES	MAXIMUM INLET PRESSURE	OUTLET PRESSURE	SOFT GOODS MATERIAL			INLET AND OUTLET PORT TYPE (VENT PORT)	INLET AND OUTLET PORT SIZE	FLOW CAPACITY	MAIN VALVE SEAT AND VENT SEAT MATERIAL	GAUGE PORT OPTIONS
			O-RING		BACK-UP RING					
			DYNAMIC	STATIC						
50-20	6 – 10,000 psig 690 bar 9 – 15,000 psig <sup>1</sup> 1034 bar	<b>Spring Load</b> 1 – 200-10,000 psig 13.8-690 bar 2 – 50-6000 psig 3.4-414 bar 3 – 25-4000 psig 1.7-276 bar 4 – 15-2500 psig 1.0-172 bar 5 – 10-1500 psig 0.69-103 bar 6 – 5-800 psig 0.35-55.2 bar 7 – 5-500 psig 0.35-34.5 bar  <b>Air Load</b> 1 – 200-10,000 psig 13.8-690 bar 2 – 50-6000 psig 3.4-414 bar 4 – 15-2500 psig 1.0-172 bar 5 – 10-1500 psig 0.69-103 bar	D – Buna-N	Buna-N	Teflon®	1 – SAE (1/4" SAE)  2 – NPTF (1/4" NPTF)  3 – MS33649 (1/4" MS33649)  4 – High Pressure (1/4" NPTF)  6 – Medium Pressure (1/4" NPTF)	4 – 1/4"  6 – 3/8"  8 – 1/2" <sup>2</sup>  9 – 9/16" <sup>5</sup>	1 – C <sub>V</sub> = 0.02 <sup>3</sup> 2 – C <sub>V</sub> = 0.06 3 – C <sub>V</sub> = 0.12 <sup>4</sup>	5 – 17-4 Stainless Steel  7 – Vespel®	0 – None   1 – 1 outlet gauge at 90°   2 – 2 gauge ports at 60°   3 – 2 gauge ports at 60° (left hand inlet)   4 – 2 gauge ports at 90°   5 – 1 gauge port at 90° (left hand inlet)  
			T – Viton®	Viton®	Teflon®					
			Z – Ethylene Propylene	Ethylene Propylene	Teflon®					

1. 15,000 psig / 1034 bar inlet requires a CTFE back-up ring on main valve, consult TESCOM  
 2. Not available in high or medium pressure  
 3. Not available for metal seated models  
 4. Not available with 15,000 psig / 1034 bar inlet with Vespel® seat  
 5. High pressure and medium pressure only