

26-1100 Series

Regulators - Pressure Reducing

D26110539X012

Specifications

For other materials or modifications, please consult TESCOM.

OPERATING PARAMETERS

Pressure rating per criteria of ANSI/ASME B31.3

Maximum Inlet Pressure

Stainless Steel Body (0.25" Orifice): 10,000 psig / 690 bar

Stainless Steel Body (0.375" Orifice): 6000 psig / 414 bar

Aluminum Body: 6000 psig / 414 bar

Brass Body: 6000 psig / 414 bar

Outlet Pressure Ranges

To maximum inlet

Design Proof Pressure

150% maximum rated

Leakage

Bubble-tight

Operating Temperature

-40°F to 165°F / -40°C to 74°C

Flow Capacity

0.25" Orifice: $C_v = 0.46$

0.375" Orifice: $C_v = 1.30$

MEDIA CONTACT MATERIALS

Body

303 Stainless Steel, 316 Stainless Steel, Aluminum, or Brass

Diaphragm

Buna-N

O-Rings

Buna-N

Back-up Rings

PTFE

Seat

CTFE

Retaining Ring

15-7 Stainless steel

Valve Cap

17-4 Stainless steel

Remaining Parts

300 Series Stainless Steel

OTHER

Cleaning

CGA 4.1 and ASTM G93

Weight (without gauges)

Stainless Steel: 10 lbs / 4.5 kg

Aluminum: 4 lbs / 1.8 kg



TESCOM 26-1100 Series is a dome load, high flow pressure reducing regulator.

Applications

- Pneumatic test consoles
- R&D laboratories

Features and Benefits

- Constant outlet pressures with variable inlet pressures
- Balanced main valve to reduce seat load which insures longer seat life
- Wide flow range capability
- Low droop; low lock-up
- Rapid response time
- Mounts in any position
- Two orifice sizes are available: 0.25" and 0.375" diameter

26-1100 Series Regulator Drawing

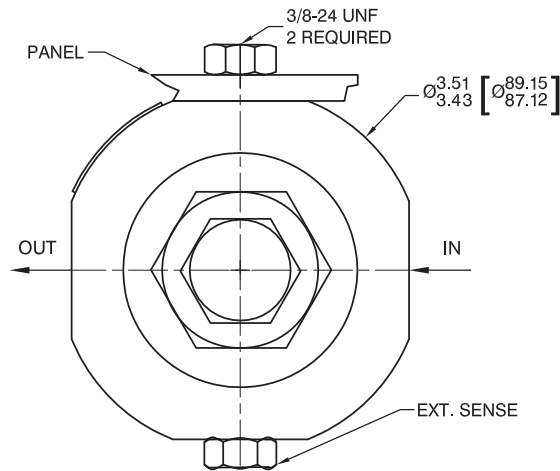
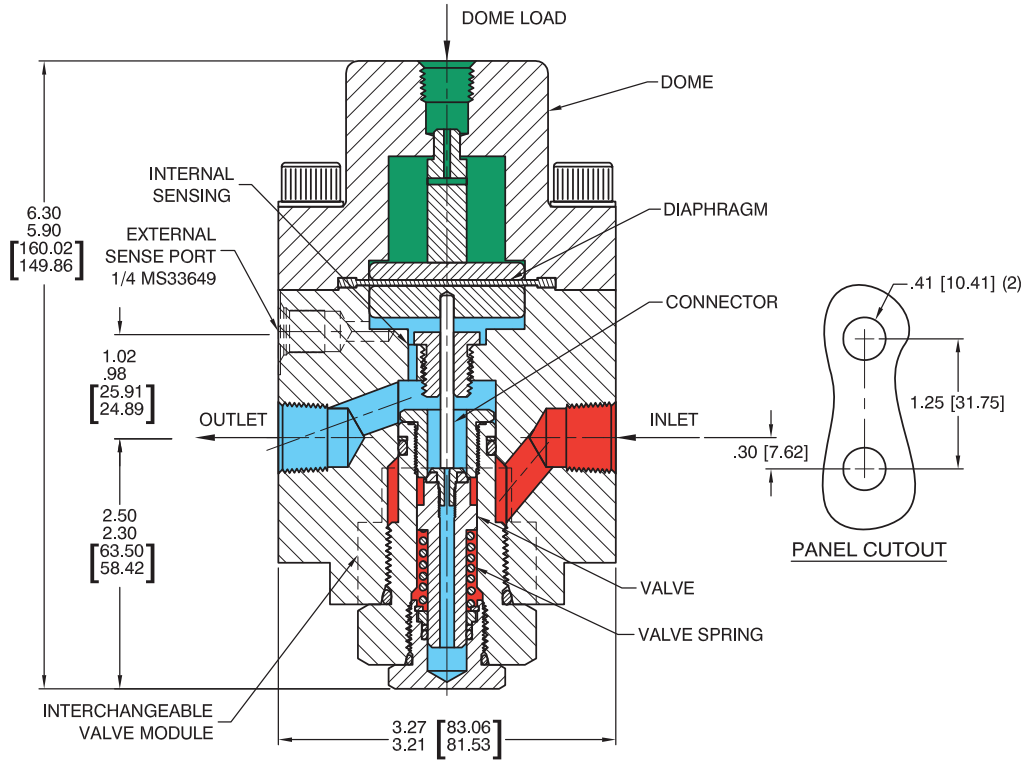

All dimensions are reference & nominal
Metric [millimeter] equivalents are in brackets

26-1100 Series Regulator Flow Charts

For more information on how to read flow curves, please refer to the Flow Curves and Calculations document (debul2007x012) in the TESCOM catalog or on www.tescom.com.

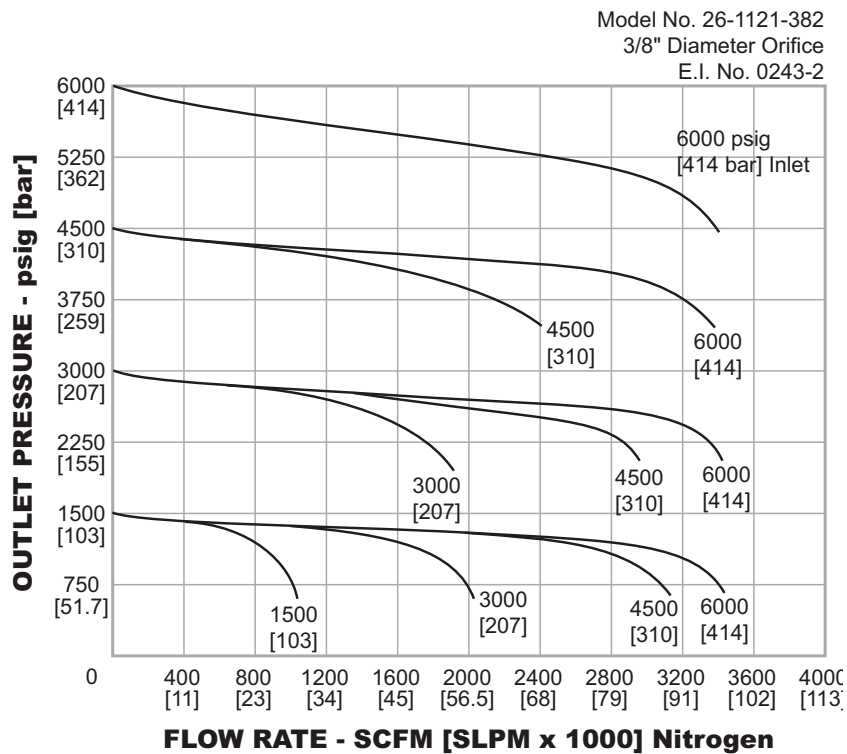
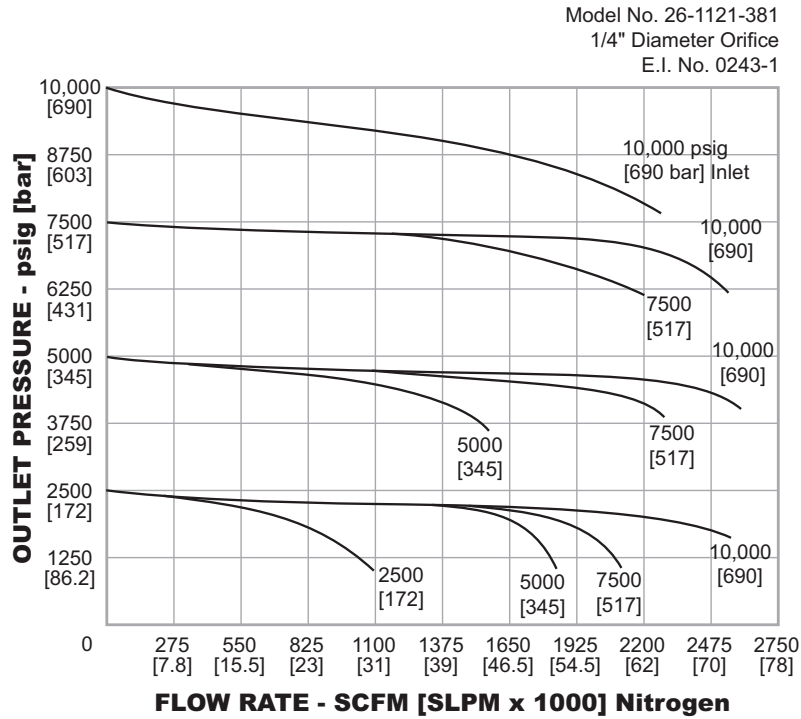

26-1100 Series Regulator Part Number Selector

Repair Kits, Accessories & Modifications may be available for this product. Please contact TESCOM for more information.

Example for selecting a part number:

BASIC SERIES	BODY MATERIAL	LOADING METHOD	INLET AND OUTLET PORT TYPE	DOVE PORT	INLET AND OUTLET PORT SIZE	INNER VALVE SIZE
26-11	1 – Brass 2 – 303 Stainless Steel 3 – Aluminum 2024-T351 6 – 316 Stainless Steel	1 – Externally loaded	1 – SAE 2 – NPTF 3 – MS33649	1/4" MS33649 1/4" NPTF 1/4" MS33649	6 – 3/8" 8 – 1/2"	1 – 0.25" Orifice 2 – 0.375" Orifice